

# Fukushima Spent Fuel Pond Failure Analysis

by W.Christoph Müller

15.May 2011

Revision 1, 27. July 2011

Revision 2, 15.Aug.2011

Revision 3, 27.Oct. 2011

[www.tec-sim.de](http://www.tec-sim.de)

mail@tec-sim.de

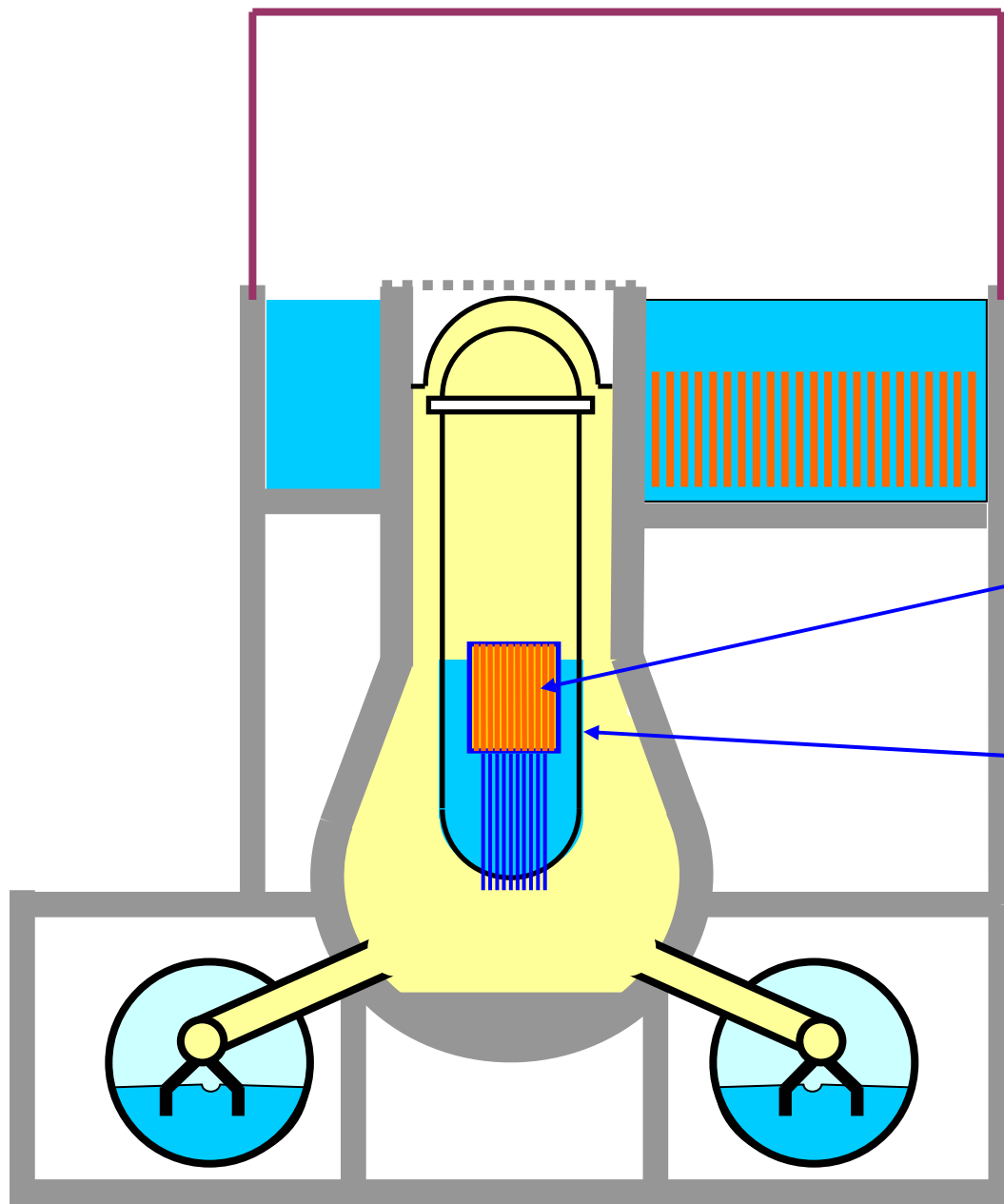

First, some facts to better understand the damage

Basically, the nuclear chain reaction in the core produces heat which makes the water boil in the reactor pressure vessel (RPV)

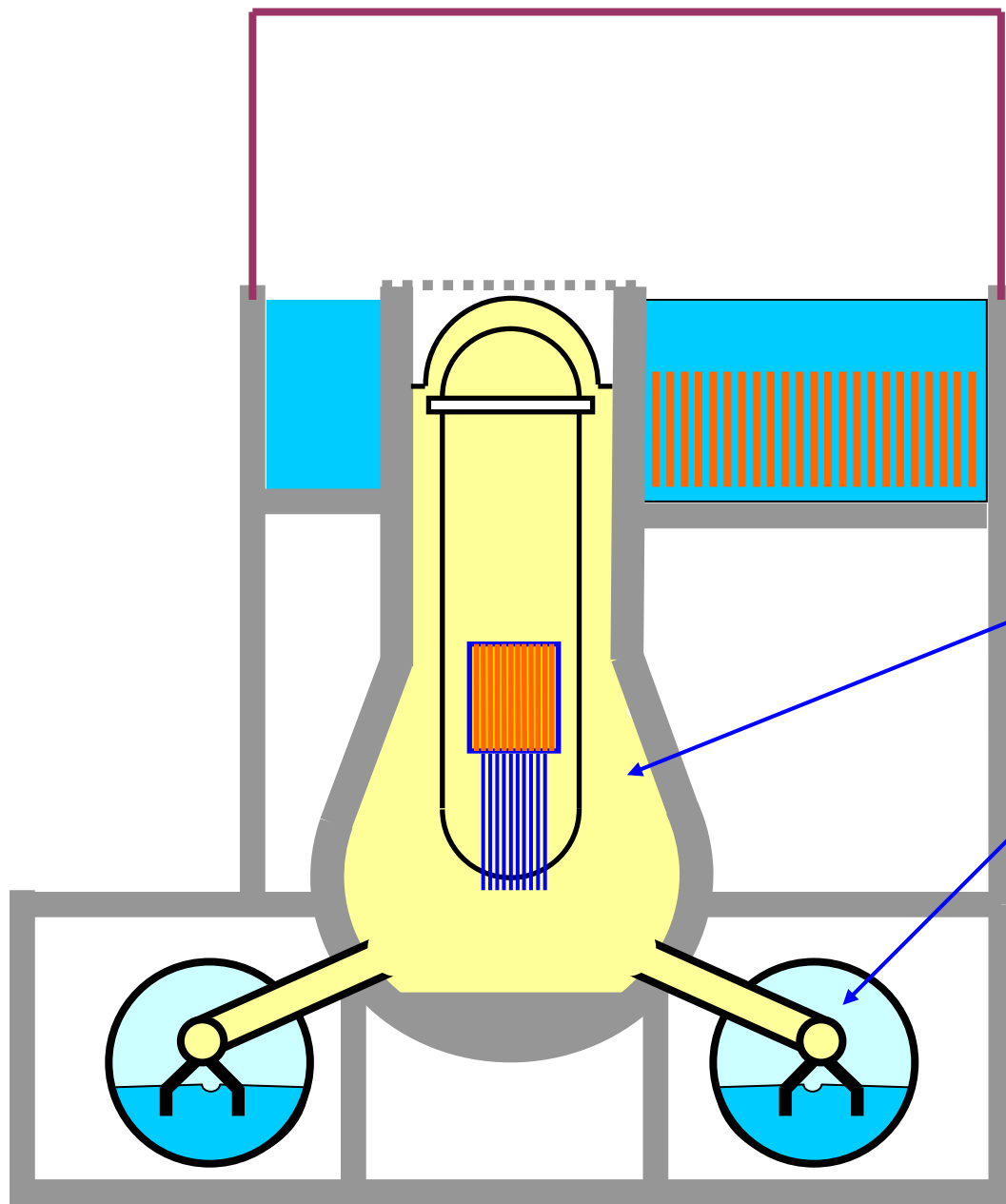

The reactor is located inside a steel containment which consists of two pressure tight compartments: The drywell (yellow) and the wetwell (blue). The wetwell or condensation chamber has the shape of a torus.

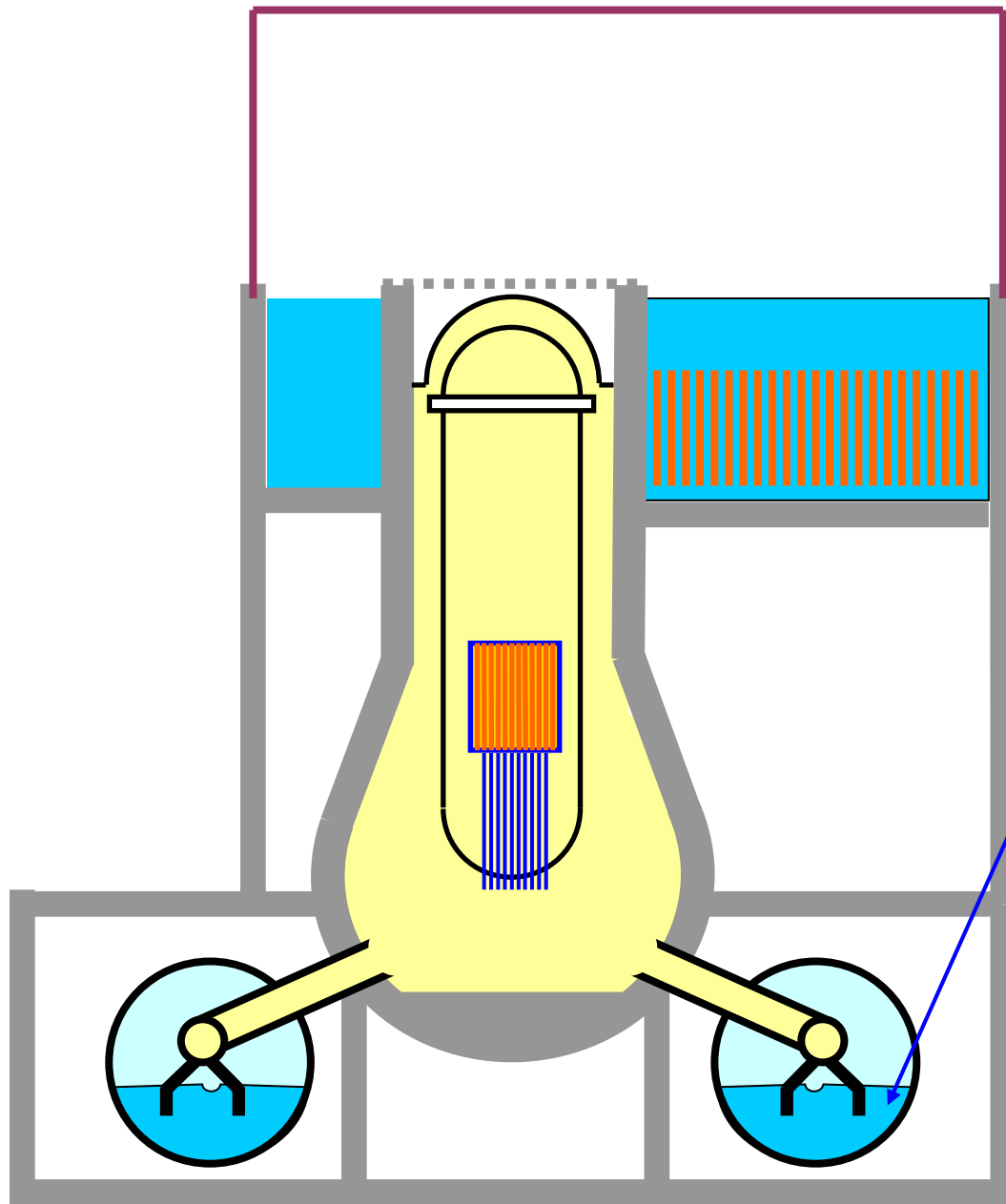

The condensation chamber is partly filled with water (dark blue) which is be used to condensate steam in case of a loss of coolant accident.

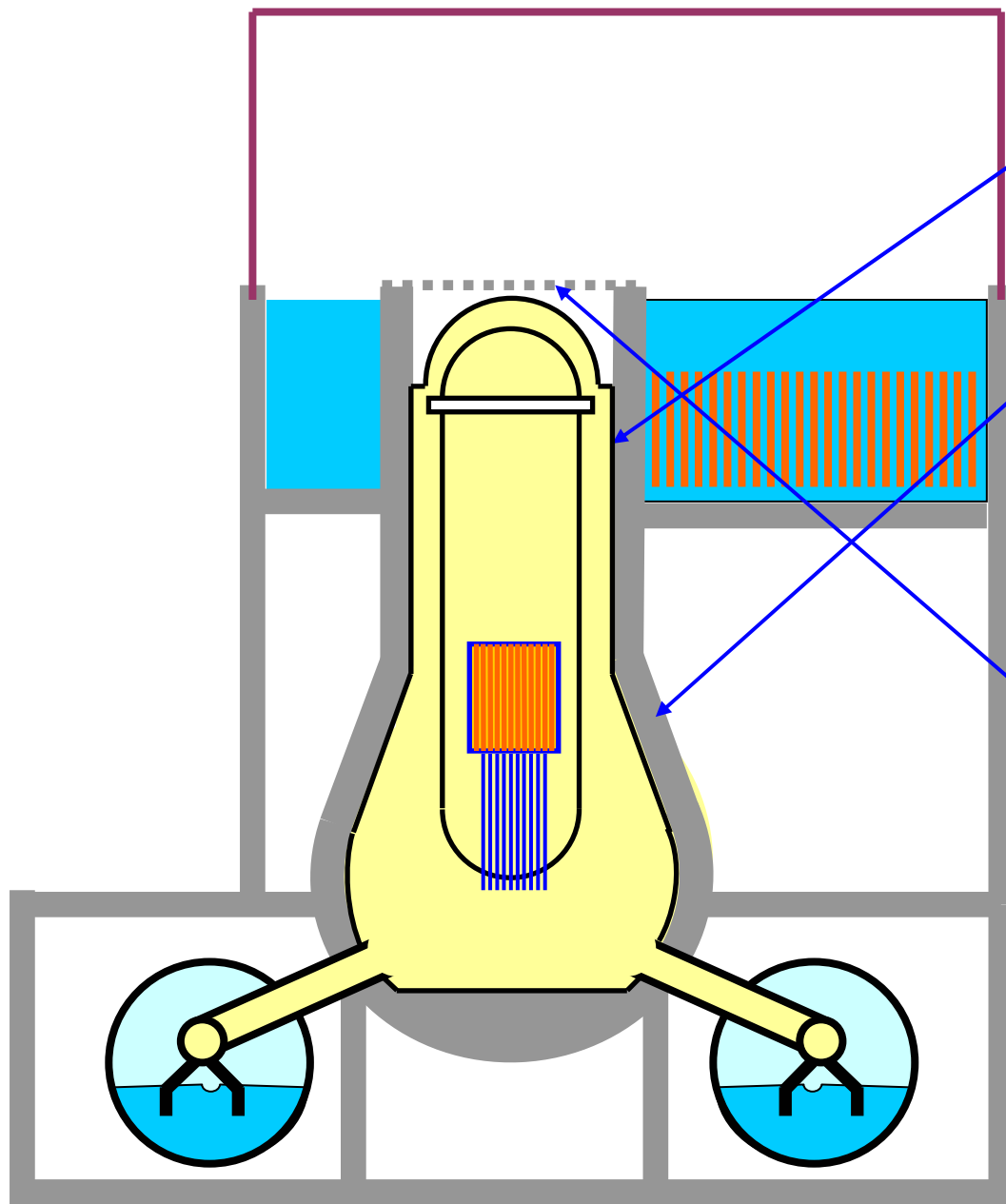

The containment is made of steel (black line) and is covered at the sides and the bottom with concrete. On top of the containment is a lid made of steel and above it are removable concrete plates.

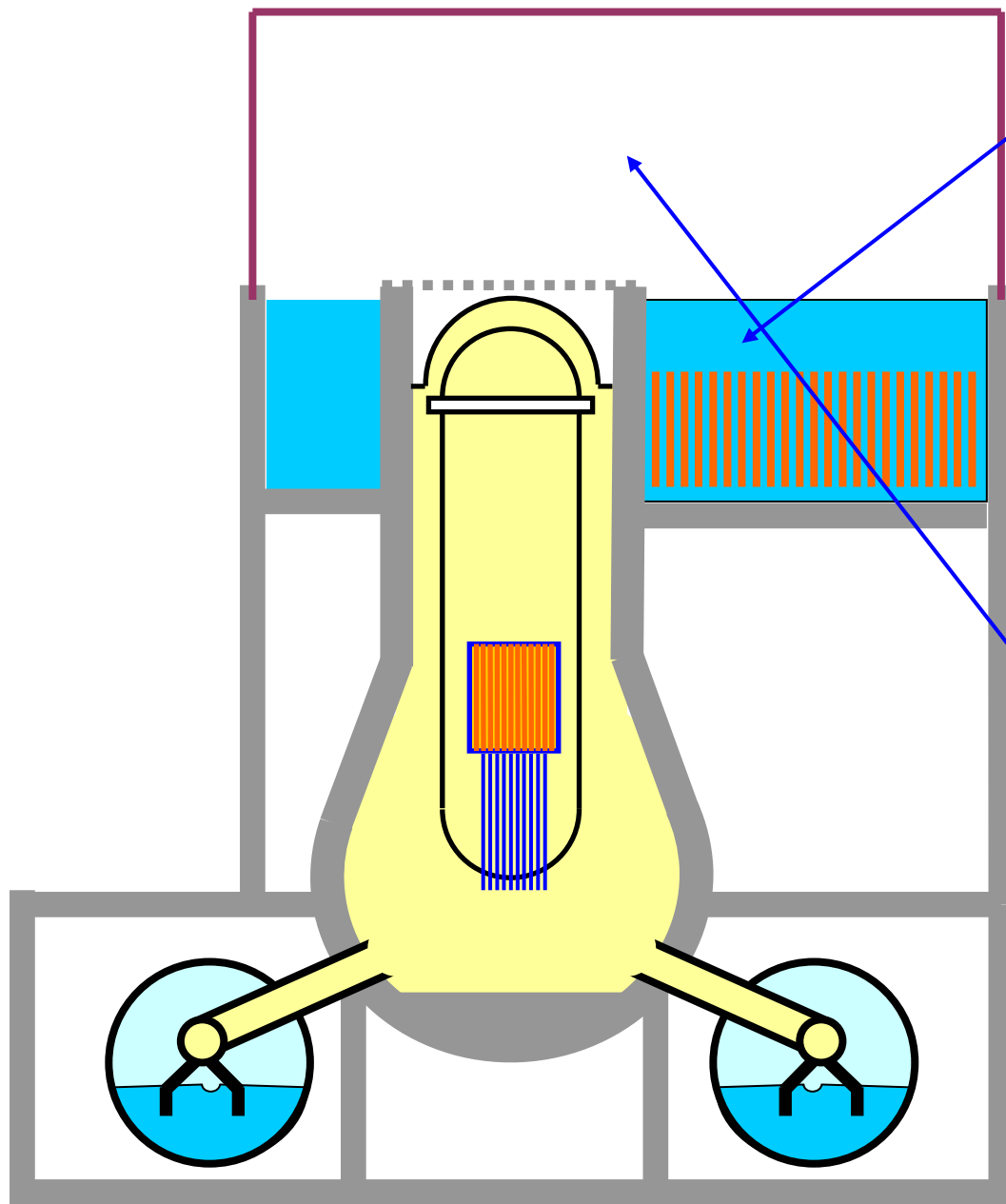

The spent fuel pond (SFP) is located on the top of the building. The building is leak tight and kept below atmospheric pressure to provide filtered air venting, but it is not pressure tight in case of pressure build up inside.

**In the accident there are some hard facts, some well founded estimates and some visual observations. These elements have to be put together to find an explanation which is in compliance with the design and the basic physics and chemistry.**

- 1) Hard facts are the time and dates of the loss of power and the destruction of the reactor buildings. Hard facts are also the design of the reactor building. Its upper part is a concrete beam and plate construction designed for external overpressure in order to have a controlled atmosphere.**
- 2) Well founded estimate is the heat production in the spent fuel ponds**
- 3) Visual observations are presented in the next slides, which give an impression of what kind of explosions or pressure surges have occurred in the buildings.**
- 4) Basic facts are that there do not exist many potential sources of explosion or pressure surge in a nuclear reactor.**

**The most important hazard is hydrogen production: hydrogen can be produced either in the reactor pressure vessel (RPV) or in the spent fuel pool. As long as the containment does not fail, no hydrogen from the RPV can escape into the reactor building.**

**A hydrogen explosion can be a detonation characterized by a shock wave or a deflagration characterized by a somewhat smoother pressure surge.**

**Another source of explosion can be a rapid evaporation, when water comes into contact with hot structures, e.g. reflooding of some overheated fuel elements.**

**The most dangerous source of explosion is a restart of the chain reaction (re-criticality), but this can be ruled out by basic physics.**



**The visual destruction is limited to the upper part of the reactor building which consists of a light weight beam and plate reinforced concrete construction.**

**From the picture it can be concluded that block 1 and 3 have experienced a detonation which caused a substantial destruction of the upper structure. Parts of the building structure were scattered over a large area and debris can be found on the roof tops of the adjacent buildings (dotted circles).**

**Block 4 experienced a minor explosion with most of the structure deformed but still in place. Debris just fell down at the sides of the building (small dotted circle).**

**Block 2 shows only minor damage: Just one plate of the upper structure has been relocated. Looks like it opened like a rupture disk.**

**The explosion in block 1 has been captured by the surveillance camera.**

**All plates and the roof were blown away while the vertical beam remained in place. From the debris and the type of destruction it can be concluded that block 1 experienced a hydrogen detonation.**

**Since the vertical plates were blown away the roof was lifted and fell back into the building forming a large amount of debris.**



**Block 2 shows only little damage.**

Only one plate was blown out and is lying below the hole (red arrow). The formation of the hole in block 2 was not observed and no explosion noise was heard that was directly connected to the hole.

The hole looks very clean cut and shows no severe deformation at its boundaries.

Basically it looks like it has been designed to fail in case of overpressure in the reactor building in order to avoid the complete failure of the building. It looks it was designed as a “rupture disk”.

This kind of destruction can only occur when the pressure build up is slow. So hydrogen deflagration is the best guess.

It could also be hypothesized that this destruction was caused by the detonation in the torus in the basement, but in this case the hole would be at the end of the staircase or the lift shaft, which is not the case.



**Added in rev3:**

**Photo of Block 2 floor 5, published by TEPCO, shows no explosion damage.**

The picture below taken in October 2011 does not show any structural damage. An explosion including a substantial pressure wave would have blown away the metal sheets around the spent fuel pool, which are still standing and showing no impact of a pressure wave at all.

The dark green crane shows the impact of heat, which has partly destroyed the dark green painting. This strongly suggests that a heat wave has occurred, caused either by hydrogen deflagration or hot steam that was generated during reflooding of the spent fuel pool.





**Block 3 experienced a severe hydrogen detonation which was captured by the surveillance camera. It shows all signs a destruction by shock wave. It was converted into typical debris with the concrete and the reinforcement steel bar fully demolished**





**Even the strong beam structure has collapsed and the heavy beams were relocated as can be seen in the picture. (red arrow). The plates were destroyed to debris and rubble while the beam structure of the roof fell back into the building.**



**The destruction of the upper structure of block 4 was not observed but an explosion noise was heard that was connected to the destruction of the 4th floor.**

**Most of the beam structure of block has remained in place -though deformed - and some of the plates also have remained in place. There is a clear contrast between block 3 and block 4.**

**Block 4 does not show the typical signs of the impact of a shock wave like the reinforced concrete turning into rubble.**

**It has to be concluded that block 4 was destroyed by a pressure surge caused either by a hydrogen deflagration or a rapid evaporation of water coming suddenly into contact with hot fuel elements.**

**The destruction is most severe close to the spent fuel pond.**



The table summarizes the findings from the analysis of the photos available from the Internet

<b>Loss of power 11.3., 15:41</b>	<b>Decay heat [MW]</b>	<b>Destruction date and time</b>	<b>Hours into the accident</b>	<b>Type of destruction</b>
<b>Block 1</b>	<b>0,7</b>	<b>12.3.,15:36</b>	<b>24</b>	<b>Hydrogen detonation</b>
<b>Block 2</b>	<b>1,8</b>	<b>15.3., 6:14</b>	<b>86</b>	<b>Hydrogen deflagration ? Pressure surge from detonation in torus?</b>
<b>Block 3</b>	<b>1,6</b>	<b>14.3.,11:01</b>	<b>67</b>	<b>Hydrogen detonation</b>
<b>Block 4</b>	<b>4,9</b>	<b>15.3., 6:10</b>	<b>86</b>	<b>Hydrogen deflagration or pressure surge</b>

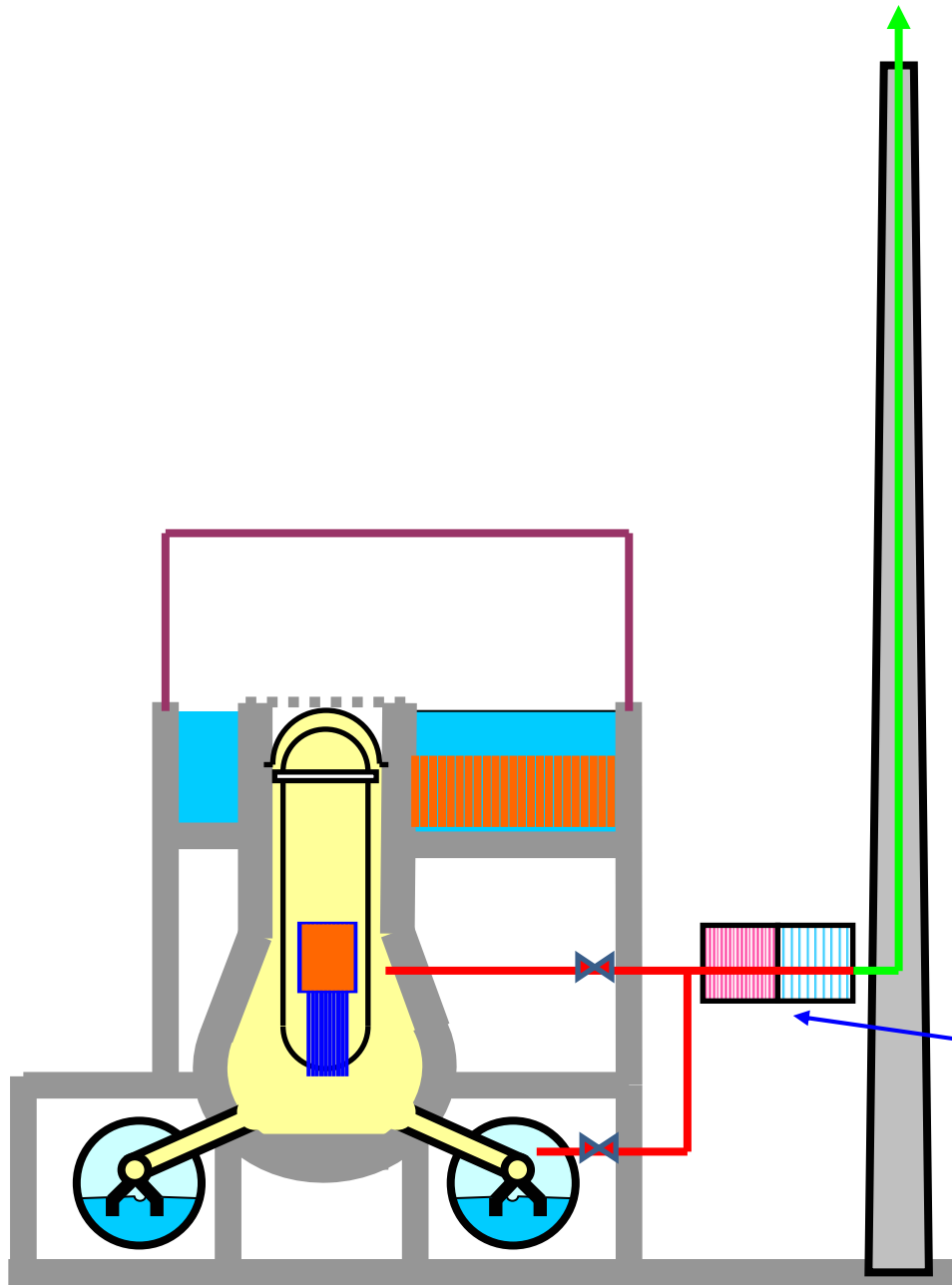

So, if hydrogen explosion caused the explosion where did the hydrogen come from. In block 1, 2 and 3 one option is that the hydrogen was generated in the RPV, escaped the RPV, escaped the containment and accumulated in the upper part of the reactor building where the spent fuel ponds are located. This has been proposed by the AREVA presentation, in which it is assumed that the hydrogen is generated in the RPV by zircon-steam interaction, is relocated to the water of the wet well by the discharge line. Instead of going up, here the hydrogen goes down to the bottom of the blowdown tubes (very strange indeed) and then rises into the upper part of the reactor building by a venting line for controlled containment venting. There is no evidence for the existence of such a venting line. There are venting lines from the wet well atmosphere and from the drywell to the stack via filters, but no other lines can be found in the design.

**In the accident there are some hard facts, some well founded estimates and some visual observations. These elements have to be put together to find an explanation which is in compliance with the design and the basic physics and chemistry.**

- 1) Hard facts are the time and dates of the loss of power and the destruction of the reactor buildings. Hard facts is also the design of the reactor building. The upper part is a concrete beam and plate construction designed for external overpressure in order to have a controlled atmosphere.**
- 2) Well founded estimate is the heat production in the spent fuel ponds**
- 3) Visual observations are presented in the next slides, which give an impression of what kind of explosions or pressure surges have occurred in the buildings.**
- 4) Basic facts are that there do not exist many potential sources of explosion or pressure surge in a nuclear reactor.  
The most important hazard is hydrogen production: hydrogen can be produced either in the reactor pressure vessel (RPV) or in the spent fuel pool. As long as the containment does not fail, no hydrogen from the RPV can escape into the reactor building.  
A hydrogen explosion can be a detonation characterized by a shock wave or a deflagration characterized by a somewhat smoother pressure surge.  
Another source of explosion can be a rapid evaporation, when water comes into contact with hot structures, e.g. reflooding of some overheated fuel elements.  
The most dangerous source of explosion is a restart of the chain reaction, but this can be ruled out by basic physics (uranium enrichment is too low).**

**So, the hydrogen has to come from the spent fuel ponds. Hydrogen in the spent fuel pond can be produced by the zircon-steam-reaction which is a strong exothermic reaction and starts when the fuel elements are not cooled properly and heat up to temperature above 1500°C.**

**In this reaction the zircon steals the oxygen from the water molecule to form zircon oxide while hydrogen is set free. Mixed with oxygen from the compartment atmosphere it may form a low enriched mixture which may start to deflagrate if ignited or a high enriched mixture which may even detonate. Basically the limits are 4% for deflagration and 20% for detonation. This reaction is limited by steam starvation.**

**The spent fuel ponds are kind of swimming pools, about 12 \* 9 m in Block 2,3 and 4 and somewhat smaller in block 1. The water level is about 11-12-meters. The fuel elements are stored in racks and about 4 m high. They are covered by about 7-8 m of water. Fuel elements coming directly from the reactor produce heat and deadly radiation. They have to be transported under water for shielding this radiation.**

**For the zircon-steam-reaction to start the fuel elements have to heat up. This is not possible as long as fuel elements in the storage are covered with water. Hydrogen can only be produced if the water level is reduced down to the top of the racks by boiling or leakage.**

## Hypothesis No 1

### AREVA Hypothesis

This hypothesis has two shortcomings:

- 1) The hydrogen in the pool has to go down to the opening of the blowdown tubes in order to flow into the drywell.

At the left torus the blowdown tubes have been omitted in order to hide this physical impossibility

- 2) The venting line from the drywell to the upper part of the reactor building cannot be found anywhere else in the drawings of a GE mark 1 reactor.

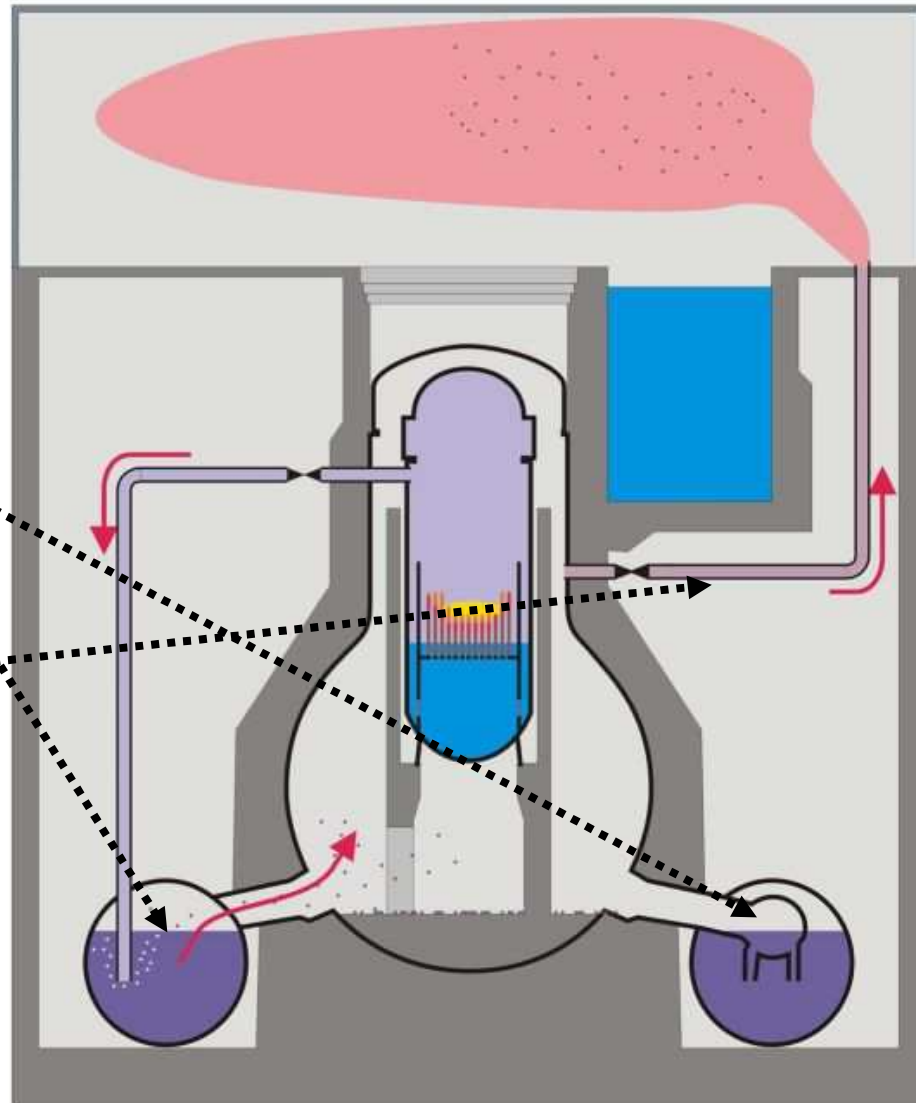

**The next question is if the ill founded AREVA hypothesis can be put on a more solid base by looking at the hydrogen generation scenario and potential flow paths inside the reactor**

**In case of insufficient cooling the hydrogen is generated inside the reactor pressure vessel by the zirconium-steam-reaction. This hydrogen can flow into the drywell through the small leaks together with steam and into the wet well through the discharge line which has been intentionally opened.**

**As long as the water in the condensation chamber is not subcooled, the steam will condensate inside the condensation pipes and no hydrogen will be carried over to the wet well. As soon as the pressure in the dry well is sufficiently high above the pressure in the wet well, hydrogen will go into the wet well.**

**In order to avoid vacuum in the dry well in case of Loss of Coolant Accident (LOCA) the condensation chamber is equipped with vacuum breakers. Vacuum breakers are swing type check valves which open due to pressure difference.**

**As soon as the pressure inside the wet well which is mostly due to the hydrogen – as long as the steam is condensed – is higher than the set point of the vacuum breakers, hydrogen will flow into the dry well.**

**Basically most of the pressure increase in the containment is not caused by steam but by hydrogen from the zirconium-steam-reaction and there is no reasonable doubt that hundreds or thousands of kilograms of hydrogen may have been generated in the accident and have escaped from the RPV in both the dry well and the wet well.**

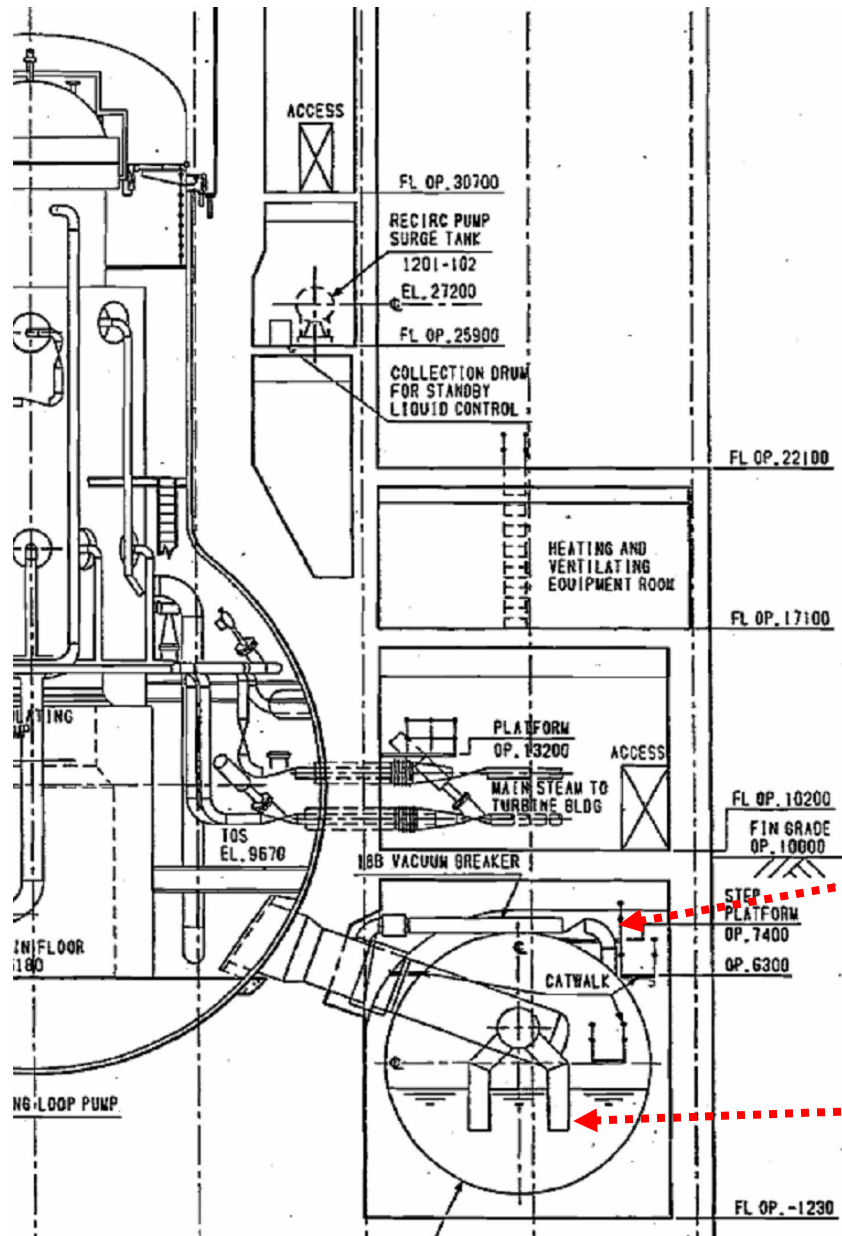

## Fukushima 1

### Position of vacuum breaker

In case of SB LOCA (small break) the steam flow is condensed at the lower opening of the condensation pipes causing "chugging"

The Fukushima reactors had been equipped in the 90s with a controlled containment venting system as recommended by the US NRS. The system is connected to both the dry well and the wet well and makes use of air operated valves actuated by the operator.

The figure from the IAEA report shows the schematics which are the same for all three units. After opening the AO valves the overpressure is discharge by a direct line closed by a motor valve and a rupture disk. There is an additional flow path using part of the SGTS (stand-by gas treatment system) which is an operational system to keep the pressure inside the reactor building below atmospheric pressure.

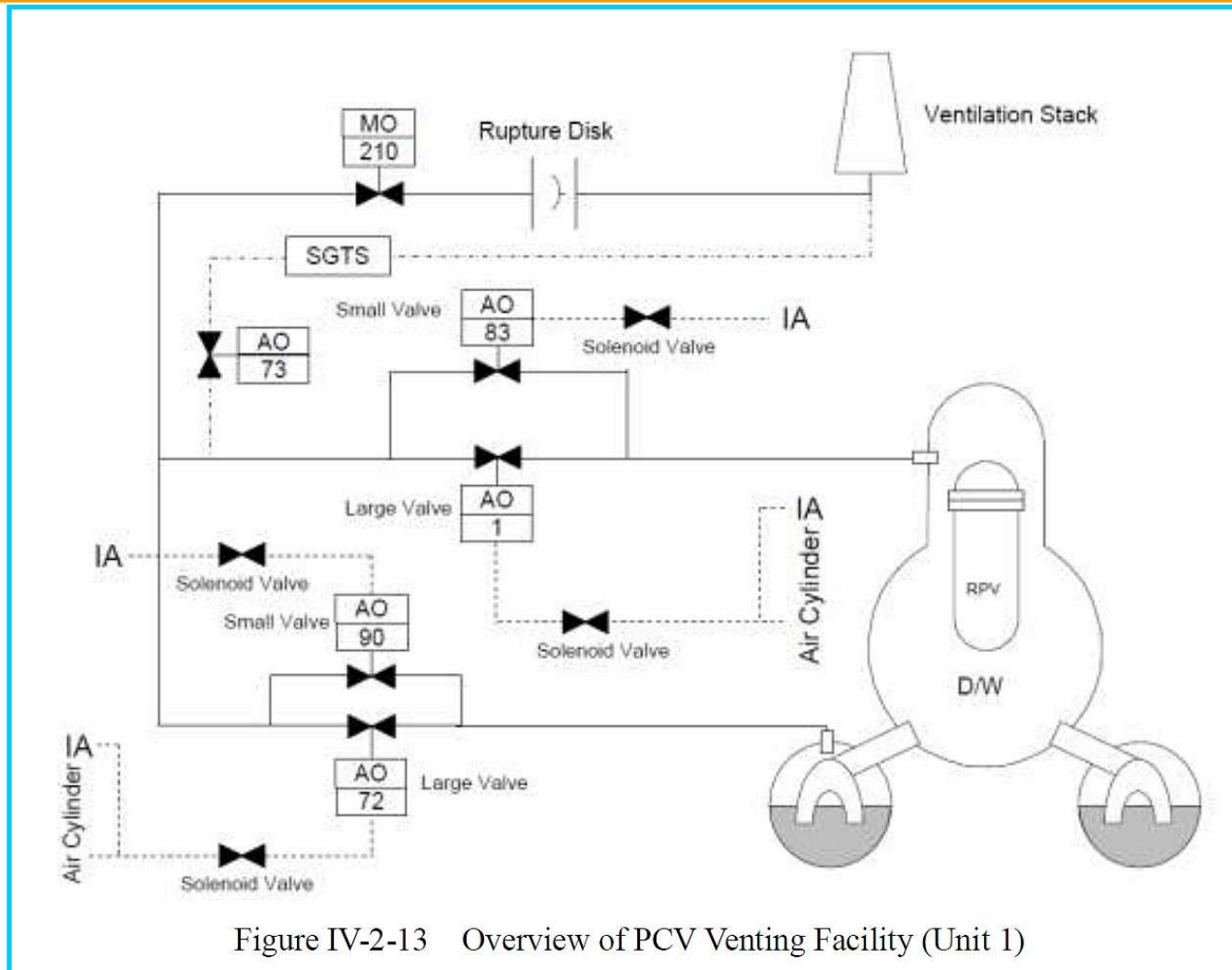

Figure IV-2-13 Overview of PCV Venting Facility (Unit 1)

It is reasonable to use the downstream part of the SGTS that includes the filters and the connection with the stack for controlled containment venting connecting the safety system for controlled containment venting with the operational system SGTS. The schematics of the SGTS of unit 4 is presented in the IAEA report and is shown later in the presentation. Basically there are flap traps everywhere upstream of the filters to prevent backflow into the rooms of the reactor building.

In case of failure of these flap traps hydrogen discharge via the downstream part of the SGTS may have partly blocked and flown into the rooms of the reactor building and up to the 5. floor.

This is reasonable to assume to have occurred in case the stack flow not working properly.

Two observations contradict this assumption:

1. Webcam footages show a white discharge cloud during the venting of unit 1 and 2. Unit 3 was vented during the night, so there is no webcam footage.
2. High radiation levels were measured in the filter room of unit 1 and in the lower elbow of the SGTD pipe at the foot of the stack, which proves that venting through the stack took place.



**As the flow path through the stack was open and worked well, it is hard to imagine that also a backward flow of the hydrogen into the SGTS occurred leading to the arrival of hundreds of kilograms of hydrogen at the fifth floor.**

**In addition to the failure of the flaps this would require a pressure build-up within the SGTS.**

**It is reasonable to assume that critical flow conditions have occurred in the first valve of the controlled venting system. It cannot be excluded that other points of critical flow condition have occurred in the flow path, e.g. in the SGTS filters. This kind of blockage may have caused a flow into the rooms of the reactor building.**

**Summarizing the above arguments it can be concluded that hydrogen may have been flowing in the downstream part of the SGTS which is also used by the controlled venting system.**

**The hypothesis that this hydrogen went in the upper part of the SGTD and arrived at the 5. floor requires two assumptions for which no evidence exists:**

- 1. Failure of the flaps in the air ducts**
- 2. Pressure build-up by multiple critical flow condition**

**So, even the improved AREVA theory is of a very low probability.**

## Hypothesis No 2: the Japanese Hypothesis

In the report

“Report of Japanese Government to the IAEA Ministerial Conference on Nuclear Safety - The Accident at TEPCO's Fukushima Nuclear Power Stations –“

([http://www.kantei.go.jp/foreign/kan/topics/201106/iaea\\_houkokusho\\_e.html](http://www.kantei.go.jp/foreign/kan/topics/201106/iaea_houkokusho_e.html)) it is hypothesized that the hydrogen explosion in block 4 was caused by hydrogen that has entered the block 4 via the standby gas treatment system.

The report shows two figures in order to explain the hypothesis:

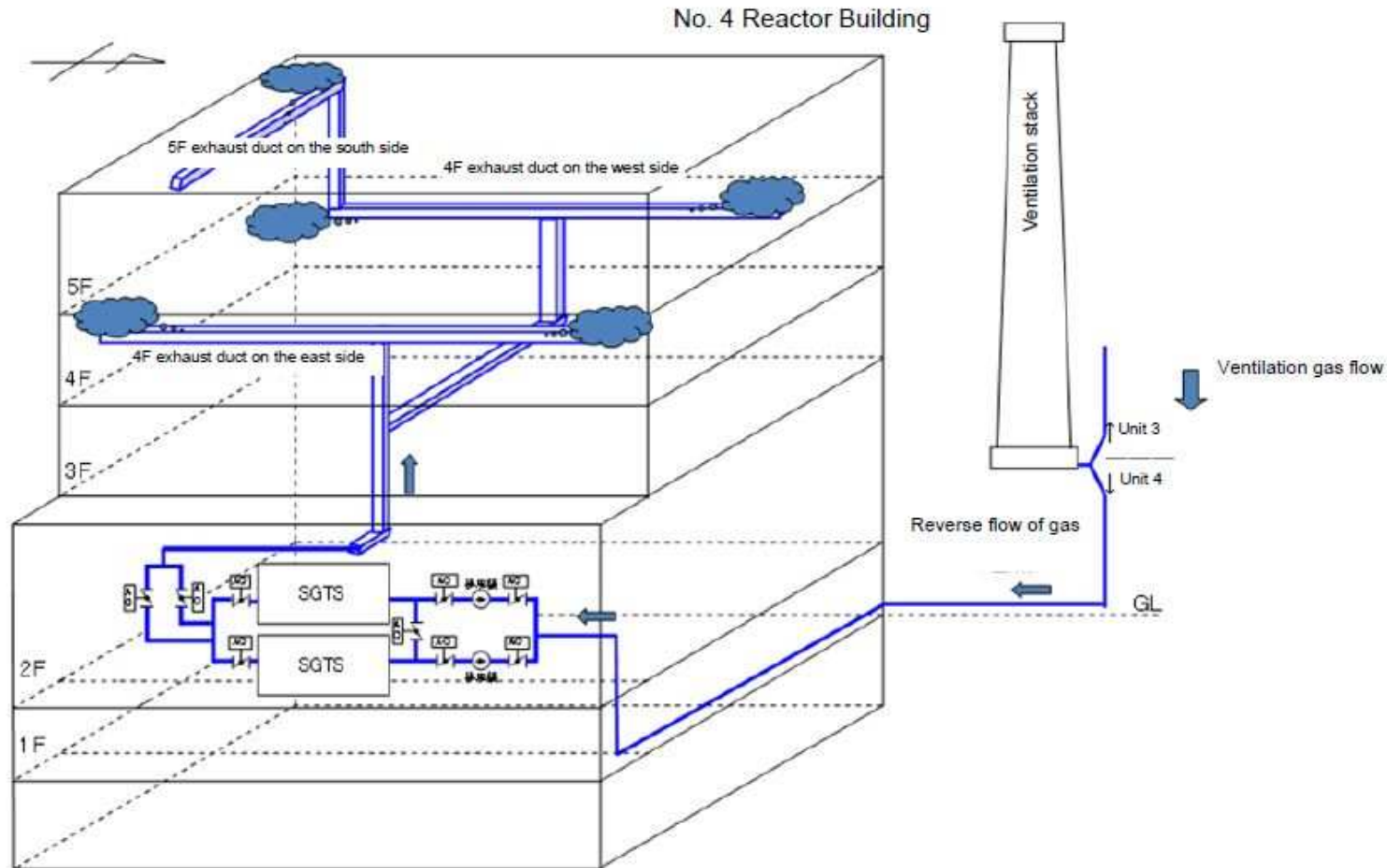

Fig. IV-5-10 Hydrogen flow route from Unit 3 to Unit 4 (estimated)

The report does not explain, why the gas did not take the short way out, but went around the corner into the next block and in spite of the flow resistance of the lines, valves, pumps and filters went all the way up the 5. floor.

One would expect that the gas flow from block 3 would go right up the stack, unless this way was blocked.

Fig. IV-5-11 Standby Gas Treatment System exhaust pipe



This figure show the exhaust pipe junction, by which the standby gas treatment system of unit 3 and unit 4 are connected.



This figure, taken shortly after the explosion of unit 3 – which is not in the IAEA report – clearly shows that the standby gas treatment pipe from unit 3 was destroyed in the explosion which occurred 19 hours before the explosion in unit 4.

This means that the hydrogen gas mixture in unit 4 had 19 hours time to mixed well due to diffusion and explosive hydrogen pockets can be excluded. It also had time enough to depressurize to ambient pressure through the open path to the destroyed line from unit 3.

The 5. floor of unit 4 has a size of about 46 m x 39 m x 14m ~ 25000 m<sup>3</sup>. Explosive limit of hydrogen is ~ 18 vol. % which requires about 4500 m<sup>3</sup> H<sub>2</sub> to form an explosive mixture in the 5. floor. This equals to 400 kg H<sub>2</sub>.

The same numbers hold for the 5. floor of unit 3 which was blown up a forceful explosion.

The Japanese hypothesis assumes the following flow path

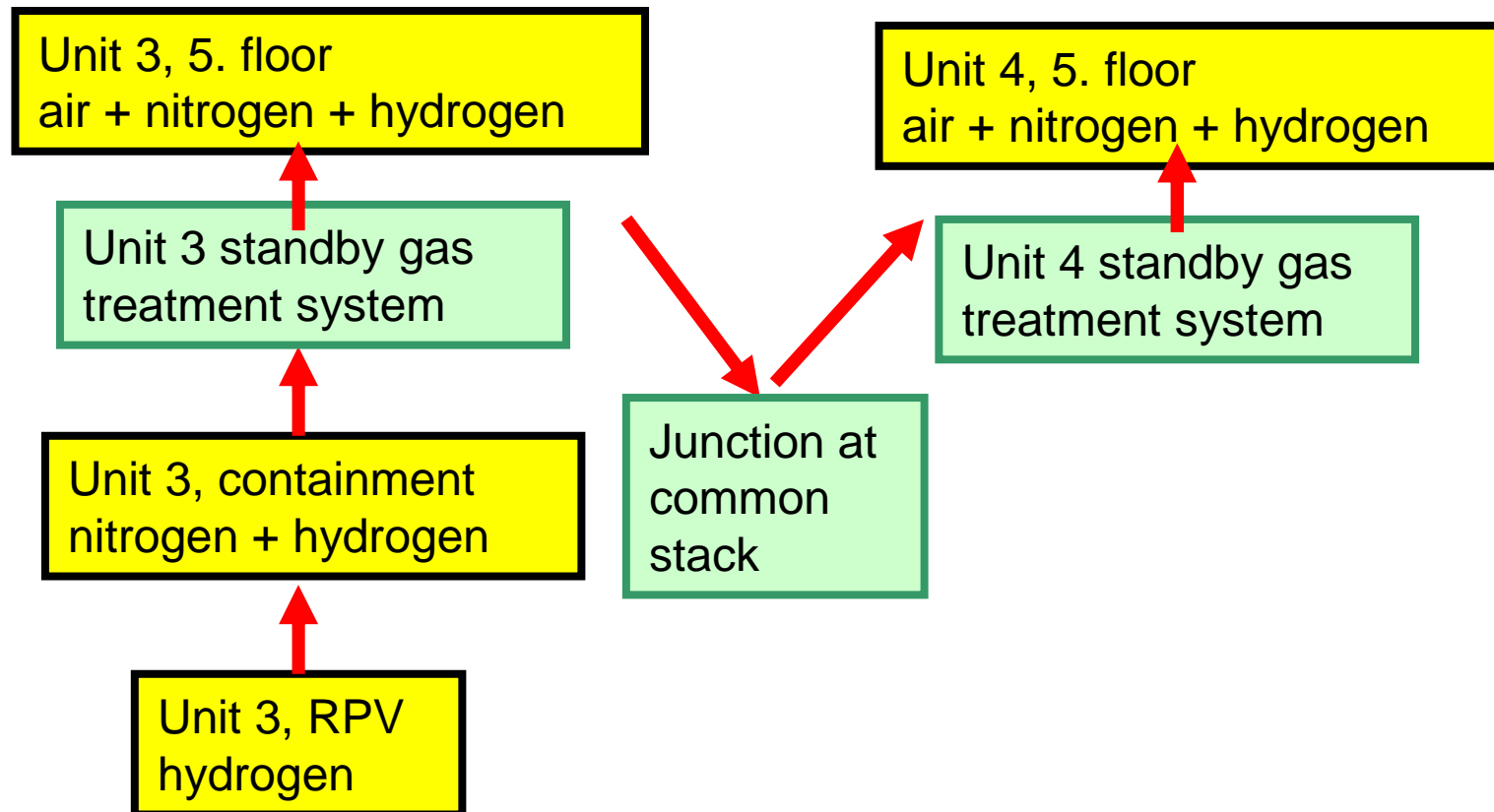

Since the reactor building is leak tight, the hydrogen reaching the 5.floor of unit 4 has to pressurize the 5.floor. Assuming the hydrogen came from the core of unit 3 and reached the 5.floor of unit 4 via the containment and the 5. floor of unit 3, it has to be well mixed with nitrogen from the containment of unit 3 and - of course – some steam and air , which is not taken into consideration here.

Assuming that 1000 kg of hydrogen have been produced by the zircon steam reaction in the core of unit 3 (~ 11000 m<sup>3</sup> normalized to 1 bar) and mixing this with the 15000 m<sup>3</sup> of nitrogen in the containment, the 400 kg hydrogen arriving in the 5. floor of unit 4 has to be accompanied by 6000 m<sup>3</sup> of nitrogen. This would pressurize the 5.floor of unit 4 up to 1.2 bar and in the depressurization after the explosion of unit 3 about 20% of the hydrogen was lost. So the total amount of hydrogen that arrived in the 5. floor of unit 4, was 500 kg if the Japanese hypothesis holds.

This back-of-the-envelope calculation requires the production of 1200 kg H<sub>2</sub> in the core, if no H<sub>2</sub> was lost in the controlled containment venting. This corresponds to the oxidization of 23 to of Zirconium in the core of unit 3. That means that about 1/3 of the total Zr inventory of the reactor (~60 to Zr) have been oxidized.

**The oxidization of 23 to of Zirconium results in the production of ~ 130000 m<sup>3</sup> H<sub>2</sub> (normalized to 1 bar ).**

**The containment pressure in unit 3 before containment venting was 4.5 bar.**

**Assuming that the dry well has ~ 10000 m<sup>3</sup> and the wet well has 5000 m<sup>3</sup>, there is an additional 1.5 bar in the wet well, which has to be contributed by the hydrogen and steam. The same must hold for the drywell. This results in a total release of a maximum of 22.500 m<sup>3</sup> hydrogen (normalized to 1 bar).**

**In view of the steam starved condition after failure of station diesels and cooling water injection this high degree of oxidization is not to be expected.**

**If the controlled containment venting was as success, most of this hydrogen must have been blown out through the stack. Only if this did not work and at least half of this hydrogen was released into the 5. floor of unit 3, the Japanese theory is feasible.**

Added in Rev3

### **Hypothesis No 3: the ENSI Hypothesis**

The Swiss Nuclear Agency (ENSI Eidgenössisches Nuklearsicherheitsinspektorat) has published a report on the severe accidents in Fukushima “Ablauf Fukushima 11032011” ([http://static.ensi.ch/1314627152/ensi\\_ablauf\\_260811\\_web.pdf](http://static.ensi.ch/1314627152/ensi_ablauf_260811_web.pdf)). In this report a third hypothesis is proposed to explain how the hydrogen might have accumulated on the 5th floor.

In this report it is assumed that the hydrogen was generated inside the RPV by zirconium-steam-reaction. ( $Zr + 2 H_2O \rightarrow ZrO_2 + 2 H_2$ ). The hydrogen was transported into the wetwell by the discharge line. When the vacuum breakers opened it flow into the drywell, where it accumulated at the top of the drywell below the containment just below the steel lid. Now either by cracks in the lid or by loss of tightness of the lid seals due to elevated temperatures the hydrogen leaked into the 5th floor.

Added in Rev3

### **Criticism of Hypothesis No 3: the ENSI Hypothesis**

The thesis that the hydrogen has accumulated at the top of the drywell just below the steel lid is in contradiction to the fundamental principle of thermodynamics that different gases mix rapidly. Only in the short time span after injection a hydrogen bubble may have formed if the temperatures were different. But this bubble would have disappeared rapidly.

The thesis that a substantial leakage through the lid or the lid seals did occur is in contradiction to the fact that the containment pressure was stable and did not decrease before the explosion. In fact, controlled containment venting has been necessary to avoid over-pressurization of the containment.

The leakage – if any – must have been small and such a small leakage would not have resulted in the release of the amount of hydrogen required to cause the observed explosions.

**Rejecting both the AREVA hypothesis, the Japanese hypothesis and the ENSI hypothesis we have to look for a different scenario, which can explain the main observations and is in compliance with the design and the basic principles of physics and chemistry.**

**We will start with an analysis of the SFPs and the heat and coolant water balances.**

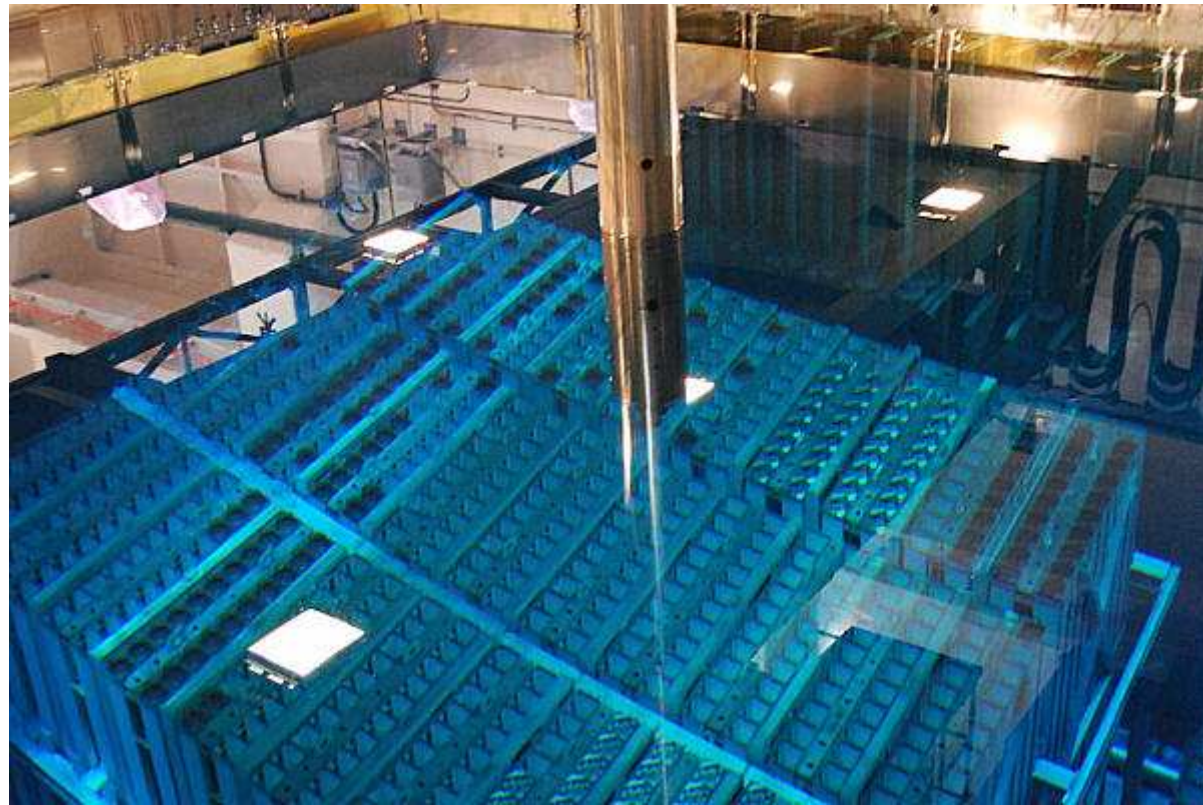
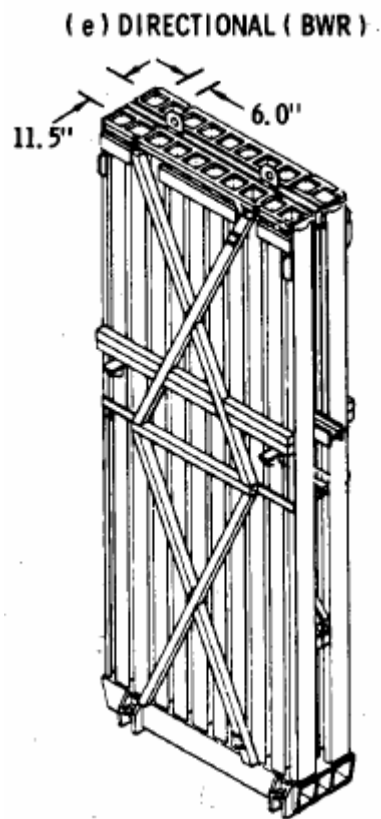

**The picture shows a Fukushima SFP. The fuel elements are stored in the typical BWR storage racks. Each element is placed in a square pipe with about 50 cm of free space below giving easy access for the cooling water.**

**In case of boiling, cooling water can enter the rack from the bottom and the top. With only little water on top counter current flow limitation will stop the top flooding.**

**The heat production in the element depends on the time since removal from the reactor core and the history of the fuel element in the core.**

Basic calculations indicate that the fuel elements cannot have been uncovered unless all four spent fuel ponds experienced a loss of coolant accident in which most of the cooling water was drained from the pool.

The next table shows the amount of cooling water that has to be lost from the pool in order to bring the water level in the SFP down to the top of the fuel (4m) starting from an estimated level of 11 m.

This analysis indicates a “missing” amount of water, shown in column 6. If this “missing” water is caused by a permanent leak, the amount of water that would have leaked in April is shown in column 7.

Since the explosions the SFPs have been repeatedly refilled but the amount of water required to keep the SFPs filled is substantially below the amount that would have been lost if the hypothesized leak before the explosions would have continued to exist after the explosions.

The table summarizes the findings from the analysis of the coolant water balance. All volumes are in m<sup>3</sup>. The last row assumes a failure of the gate seals between the SFP and the reactor pit in block 4.

<b>Loss of power 11.3., 15:41</b>	<b>Estimated volume</b>	<b>Hours into the accident</b>	<b>Hours to boiling</b>	<b>Hours to top of fuel</b>	<b>Missing amount of water</b>	<b>Necessary refill in April</b>
<b>Block 1</b>	<b>900</b>	<b>24</b>	<b>104</b>	<b>559</b>	<b>532</b>	<b>15955</b>
<b>Block 2</b>	<b>1300</b>	<b>86</b>	<b>58</b>	<b>314</b>	<b>680</b>	<b>5691</b>
<b>Block 3</b>	<b>1300</b>	<b>67</b>	<b>66</b>	<b>353</b>	<b>765</b>	<b>8226</b>
<b>Block 4</b>	<b>1300</b>	<b>86</b>	<b>22</b>	<b>115</b>	<b>200</b>	<b>1674</b>
<b>Block 4 SFP + reactor pit</b>	<b>2600</b>	<b>86</b>	<b>43</b>	<b>230</b>	<b>1158</b>	<b>9698</b>

**The numbers in the table show that the fuel elements can not have been uncovered unless a substantial leakage has occurred in the SFP. The heat produced by the fuel elements in the SFP is not strong enough to have led to a boil off to the top of the fuel in such a short time. Therefore a leak in the SFP has to be hypothesized.**

**On the other hand, after the explosion the leakage must have been substantially reduced since the water filled in the SFP is considerable less than the amount of water that would have leaked if the leak remained the same after the explosion.**

**Based on the experience that there are no accidents without precursor accidents the report NUREG 1275, volume 12 "Operating Experience Feedback Report: Assessment of Spent Fuel Cooling", has been evaluated in search of potential candidates for loss-of-coolant inventory events.**

**In addition the failure of all four SFP has occurred more or less according to the same time line indicating a CCF (Common Cause Failure) as the origin of the leakage.**

*Loss-of-Coolant Inventory Events from:  
Operating Experience Feedback Report: Assessment of Spent Fuel  
Cooling, NUREG-1275, Volume 12*

**Table 3.2 Loss-of-Coolant Inventory Events**

Type of Event	Actual	Precursor
<u>Connected Systems</u>	<u>20</u>	<u>12</u>
Configuration Control	16	2
Siphoning	3	1
PWR Transfer Tube	1	1
Piping	0	1
Piping Seismic Design	0	7
<u>Gates and Seals</u>	<u>10</u>	<u>8</u>
Cavity Seals	0	6
Gate Seals	10	2
<u>Pool Structure or Liner</u>	<u>8</u>	<u>35</u>
Liner Leaks	7	1
Load Drops	1	32
Pool Seismic Design	0	2

From this list three good candidates can be found:

1. Liner Leaks
2. Gate seals
3. Siphoning

The favorite option “configuration control” can be eliminated because the operators did not take any actions until battery power ran out.

The configuration control events are quite similar to the one in Millstone:

*At Millstone Unit 2 on July 6, 1992, about 10,000 gallons of SFP water was drained to the reactor coolant system (RCS). At the time of the event, the unit had been shut down about 37 days and the full core had been placed in the SFP. A loss of normal power resulted in loss of SFP cooling. During the response to the event, the operations staff decided to align the shutdown cooling system to provide cooling to the SFP. However, during the alignment process, a flow path was created that permitted flow via a gravity drain from the SFP to the RCS. The SFP water level dropped about 14 inches.*

## **Option 1: Liner Leaks**

Basically a liner leak consists in a failure of a liner weld in connection with a fracture of the reinforced concrete structure.

Even if a liner weld failure had occurred in the earthquake, this failure is very unlikely to be connected with a fracture of the concrete structure at the same location. And even if a fracture in the reinforced concrete has occurred, the reinforcement steel bars will close again any fracture gap.

If the gaps are not closed again, the leak would remain open and there is not good explanation why the leak should be fixed after the hydrogen explosion.

So we can delete this option from the list.

## **Option 2: Gate seals (1)**

A possible source of the leak could be the seals around the gates on one side of the SFP. They are located between the pool and the area above the reactor vessel (reactor pit). When fuel is moved between the pool and vessel, the reactor pit is filled with water, the gates are opened, and the fuel can be moved to or from the reactor core while remaining under water.

The closed gates are made watertight by an inflatable seal, similar to a bicycle innertube. Electric compressors are used to keep these tubes inflated to replace leakage of air.

Since the whole system is not a class 1 safety system, the compressors do not have power backup by diesels or batteries.

In case of station blackout they will lose the air sooner or later and water will leak from the SFP to the reactor pit and back.

Position of the gates from NUREG 1275 Vol.12

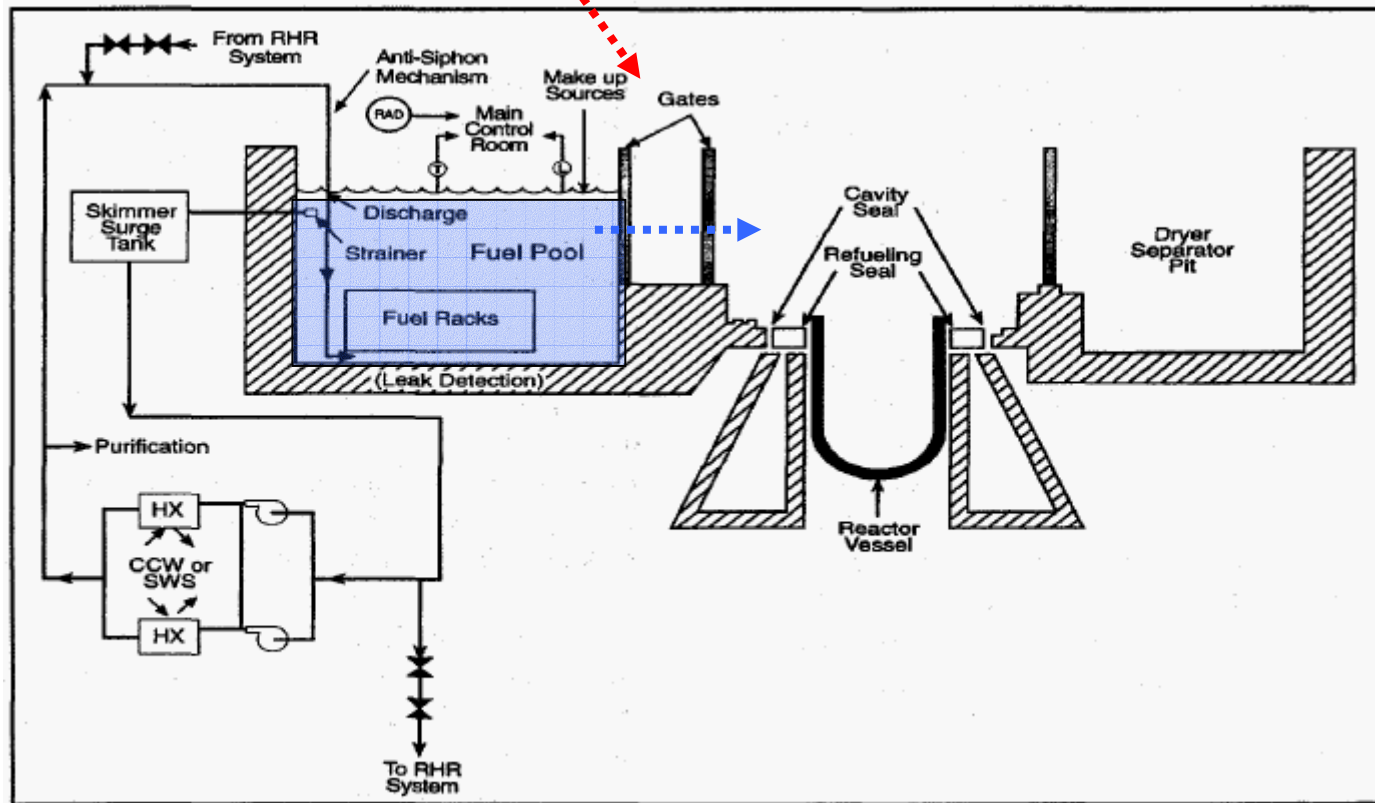

Figure 2.2 BWR Spent Fuel Cooling Systems

## **Option 2: Gate seals (2)**

As can be seen from the next figure, the designer have taken this safety issue into account and designed the adjacent pits in such a way that the water does not leak below the top of the fuel elements. So the cooling water is not lost, it is only distributed in a different way. If the SFP level is going down the cooling water will flow back into the SFP and be available for the cooling process.

In order to loose cooling water we have to hypothesize a second leak in the reactor pit. This is only feasible by a leak from the reactor pit to the drywell. This path is closed by bellows which look failsafe.

When assuming a leak in the reactor pit this leak will remain open in case of hydrogen explosion. There is no explanation why the leakage stopped after the hydrogen explosions.

So we can delete this option from the list.

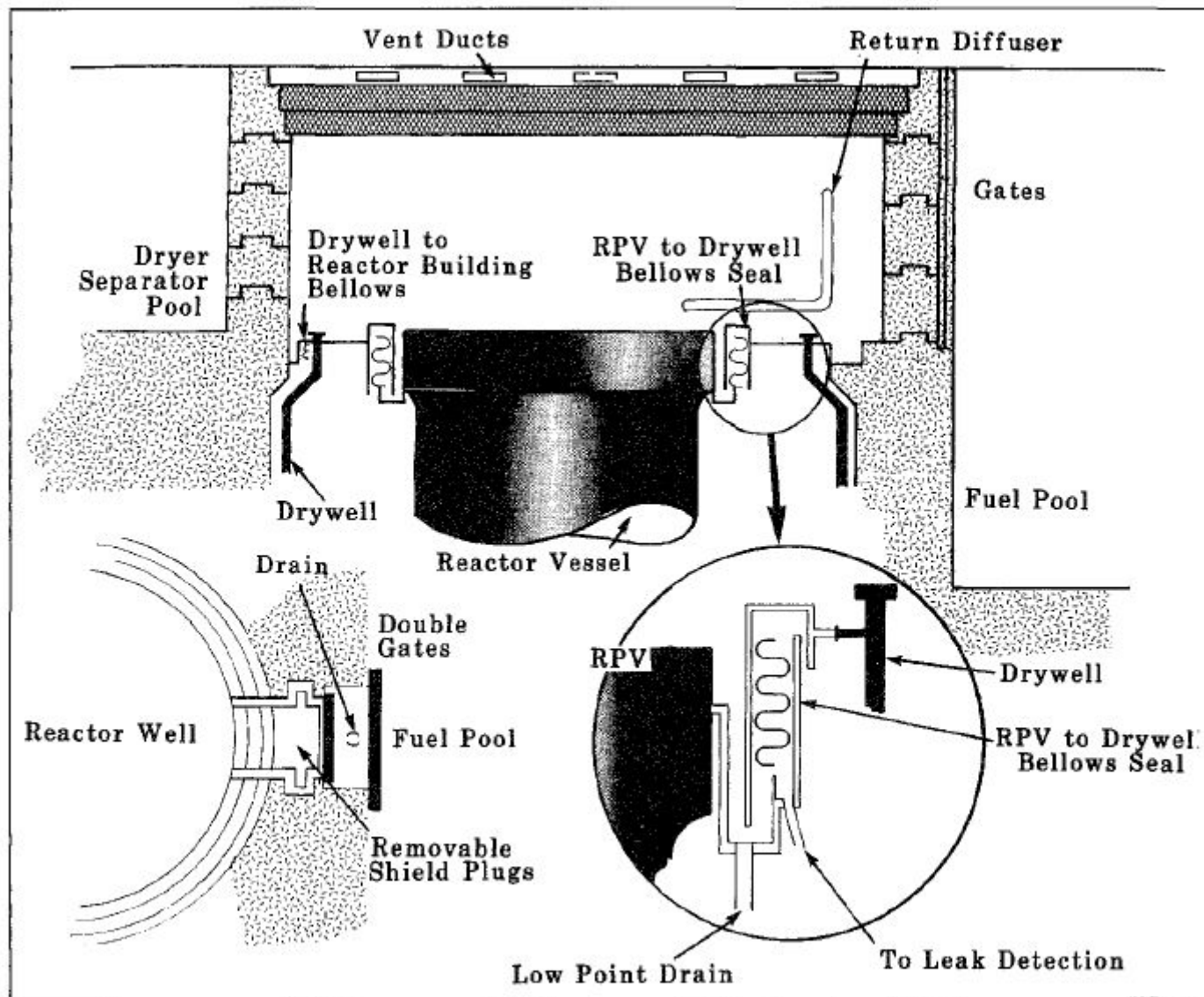

**Figure 8-1** Reactor Well Seals

Details of the gate from Oyster Creek, view from the top

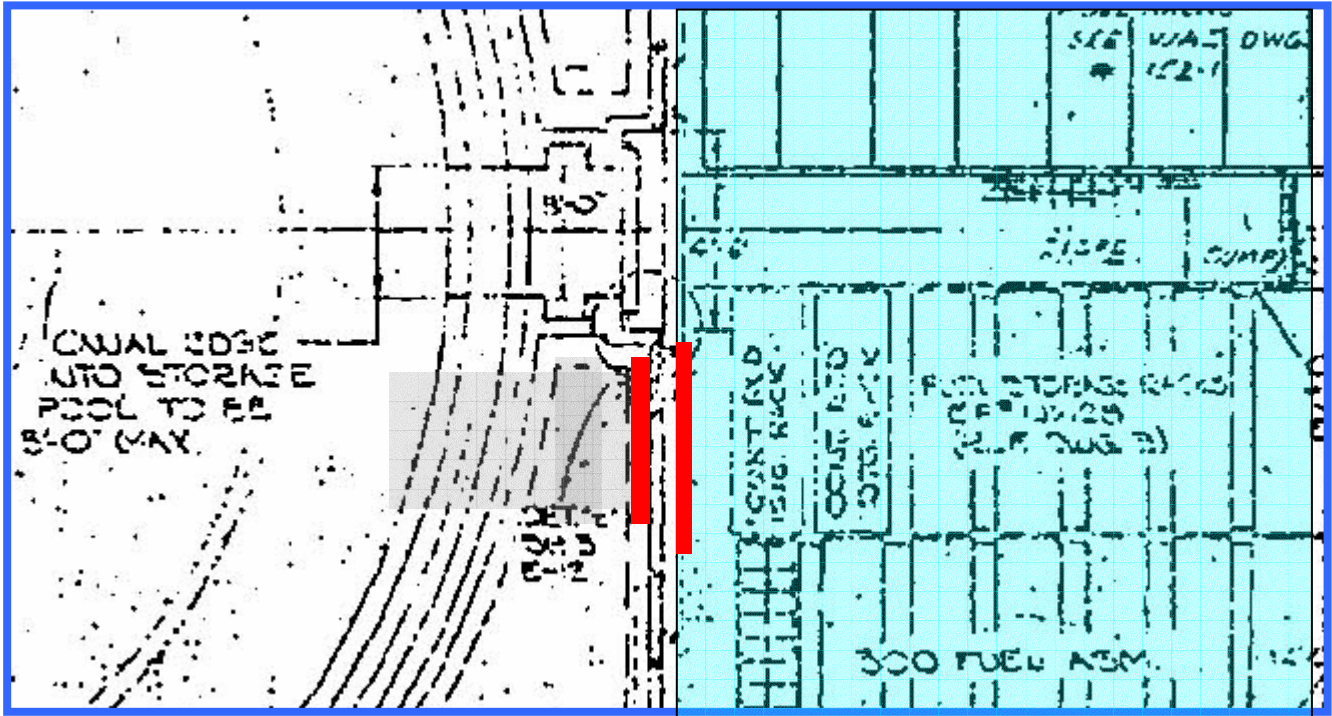



### Option 3: Siphoning (1)

The basic idea of SFP safety is to build it like a swimming pool with no penetration at the sides and the bottom. The cooling water is fed to the pool by a feed line coming from below, entering the pool in form of an U-shaped line and going down to the bottom of the SFP where it is distributed by a horizontal line with holes.

The water level is controlled by a horizontal line leading to the skimmer surge tank (small tank on the right)

If the water level falls below the set point the liquid water level switch open the feed line to replace the lost water.

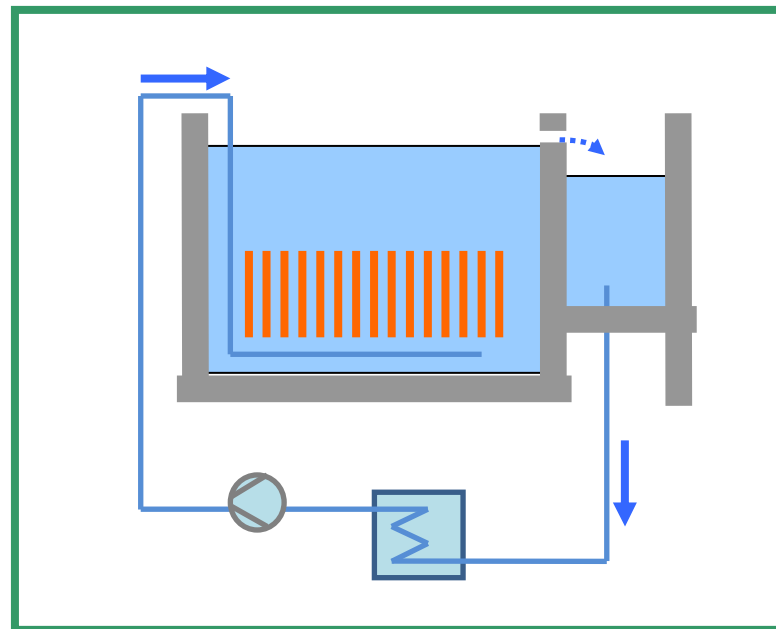

### **Option 3: Siphoning (2)**

In case that the feed water flow is stopped and the feed line is not closed by a check valve, reverse flow in the feed line may occur draining the SFP by gravity induced flow. This is the phenomenon of “siphoning”. In order to prevent siphoning some anti-siphon mechanism has to be provided.

The next figure shows the design scheme for the GE Mark I Susquehanna Plant in normal operations (green) and emergency operations (red).

This figure shows liquid level switches but no check valves to prevent siphoning. It also shows a lot of connections to other system and tanks in case of emergency operation: pressure suppression pool and ESW.

From the figure it can be concluded that in case of emergency operation and loss of battery power the pumps will stop and the motor valves remain open. In this case siphoning may suck the water from the SFP on the top of the building to some tanks or systems below.

Design scheme of SFP cooling in Block 1 and 2 of Susquehanna GE Marl I plant,  
 from David Lochbaum "Nuclear Waste Disposal Crisis" PennWell Books, 1996  
 (Normal operation = green, emergency operation = red)

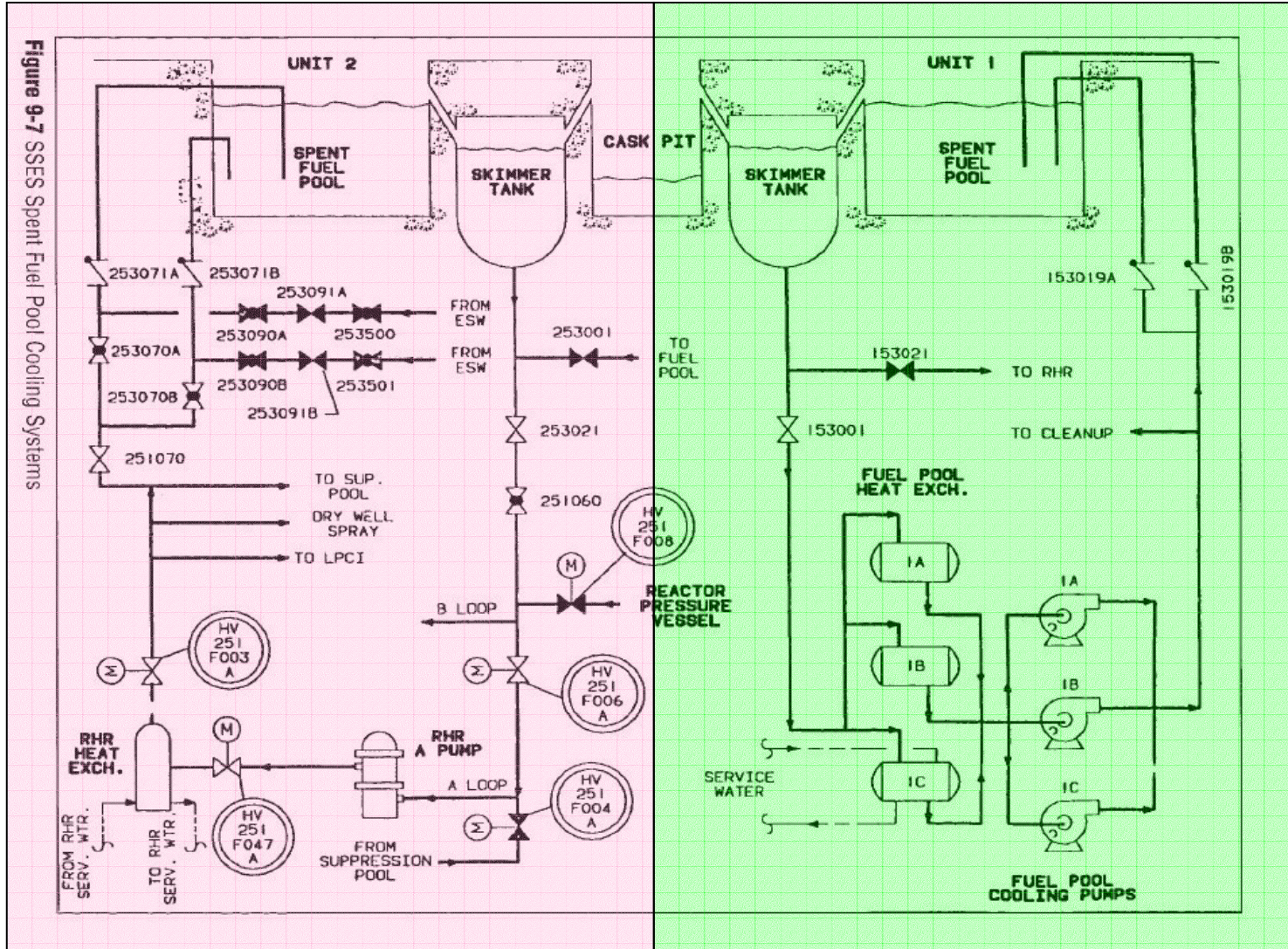

## Remarks concerning anti-siphon devices

1. GE BWRs have been originally built without anti-siphon devices. Some BWRs have been equipped later with siphon protection either by drilling holes into the downward leg of the feed pipe or by adding anti-siphon valves in the horizontal leg which open when the pressure at the top of the pipe drops below atmospheric pressure. Both systems have been reported to fail in the past. So even if such a device has been installed it cannot be considered as fail safe.
2. After the Fukushima Accident NRC has asked all BWR operators to report on their siphon and drain protection, which indicates that the NRC has not requested the installation of siphon and drain protection in the past. From this information it seems plausible that the Japanese BWRs may not have been equipped with siphon and drain protection. Some operators seem to have installed non-reversible pumps. It is not known if this might help in case of black-out.
3. It may be assumed that the swing type check valves in the figure above are designed for siphon and drain protection. But in this case they are presented to operate in the wrong direction and placed in the wrong position. They should operate in the direction away from the pool and should be placed in the horizontal leg of the feed pipe. It seems more reasonable to assume that they may constitute some kind of „surge protection“ in case of faulty operation of the hand operated valves below.

### **Option 3: Siphoning(3)**

NUREG 1275 , Volume 12 lists several cases of siphoning.

- 1. One event at River Bend on September 20, 1987, (Ref. 8) involved plugging of a single (nonredundant) vertical vent pipe acting as an antisiphon device. In this event, the SFP coolant loss was due to siphoning, but was masked by the SFP low-level annunciator being in the alarm condition because of other ongoing plant work.*
- 2. In another event at San Onofre Unit 2 on June 22, 1988 (Ref. 9), about 9000 gallons of SFP coolant drained from the SFP to the reactor cavity through the SFP purification system because that system lacked siphon protection. This event lasted about 5.5 hours.*
- 3. One precursor event was reported in which antisiphon holes in the two SFP cooling return lines were not present even though 0.5-inch holes were previously thought to exist.*

From this experience it has to be concluded that siphoning has occurred.

### **Option 3: Siphoning(3)**

NUREG 1275 , Volume 12 lists several cases of siphoning.

- 1. One event at River Bend on September 20, 1987, (Ref. 8) involved plugging of a single (nonredundant) vertical vent pipe acting as an antisiphon device. In this event, the SFP coolant loss was due to siphoning, but was masked by the SFP low-level annunciator being in the alarm condition because of other ongoing plant work.*
- 2. In another event at San Onofre Unit 2 on June 22, 1988 (Ref. 9), about 9000 gallons of SFP coolant drained from the SFP to the reactor cavity through the SFP purification system because that system lacked siphon protection. This event lasted about 5.5 hours.*
- 3. One precursor event was reported in which antisiphon holes in the two SFP cooling return lines were not present even though 0.5-inch holes were previously thought to exist.*

From this experience it has to be concluded that siphoning has occurred.

The table calculates the leak rate from siphoning before the explosions. Since it is reasonable to assume that the inflatable gate seals in block 4 have failed due to loss of power, the amount of water in the reactor pit has to be taken into account in the analysis. The leak rates are reasonable and similar for the block 2 to 4, which are of the same size. Block 1 shows a higher leak rate, the reason for this is unknown.

<b>Loss of power 11.3., 15:41</b>	<b>Estimated volume</b>	<b>Hours into the accident</b>	<b>Missing amount of water</b>	<b>Siphoning rate m3/h</b>
<b>Block 1</b>	<b>900</b>	<b>24</b>	<b>532</b>	<b>22,1</b>
<b>Block 2</b>	<b>1300</b>	<b>86</b>	<b>680</b>	<b>7.9</b>
<b>Block 3</b>	<b>1300</b>	<b>67</b>	<b>765</b>	<b>11.4</b>
<b>Block 4</b>	<b>1300</b>	<b>86</b>	<b>200</b>	<b>2.3</b>
<b>Block 4 SFP + reactor pit</b>	<b>2600</b>	<b>86</b>	<b>1158</b>	<b>13.5</b>

### **Option 3: Siphoning (4)**

#### **Hypothesized scenario (a):**

After station blackout, the operators changed to emergency operations and connected the SFP cooling system to the RHR system running it on battery power.

The liquid level switches were open due to water level loss by evaporation or inflatable gate seal leakage.

When the batteries ran empty, the pumps stopped and the motor valves remained open providing an open path to the tanks and system below the SFP.

Siphoning started and the SFP water inventory was drained from the SFPs into the lower open parts of the system, most likely to the pressure suppression pool or to a storage tank.

When the water level reached the top of the fuel rack the hottest fuel elements were overheated and dried out.

With each fuel element in its own separated section the cooling inside the section broke down, the zircon-steam-reaction started and the fuel element burnt like a torch.

### **Option 3: Siphoning (5)**

#### **Hypothesized scenario (b):**

The hydrogen resulting from the reaction mixed with the atmosphere of the fourth floor and eventually ignited.

The resulting deflagration or detonation destroyed partly or totally the light weight structure of the fourth floor walls and roof.

The pressure wave from the explosion also traveled into the feed line.

An explosion pressure wave is made up of an initial short and high pressure peak followed by a longer underpressure period.

The overpressure will accelerate the drain flow but the underpressure will cause evaporation at the highest section of the siphon and break the water column into two. This will stop the siphoning.

This effect would explain why the leakage stopped after the explosions.

### **Lack of damage in fuel elements (1)**

One puzzling observation in the SFP of block 4 is the lack of observable fuel damage as shown in the picture published by TEPSO in support of the hypothesis that the hydrogen explosion in block 4 was caused by hydrogen from block 3.



## **Lack of damage in fuel elements (2)**

Typically the scenarios with zircon steam reaction are characterized by a temperature escalation due to exothermic oxidation.

In BWR scenarios there is one scenario with this temperature escalation. The characteristics of this sequence is loss of off-site power, failure of station diesels and steam driven turbine injection system which results in: no injection, vessel depressurized, boil off with flashing during depressurization and steam starved core degradation. This scenario has been investigated in the KfK CORA 33 experiment. The figures shown the results of CORA 33 in comparison to a typical scenario without steam starvation.

This scenario is quite similar to what is to be hypothesized in case of loss of coolant of the SFP by siphoning.

### Lack of damage in fuel elements (3)

Comparison of temperatures and hydrogen production in CORA 33 and CORA 31

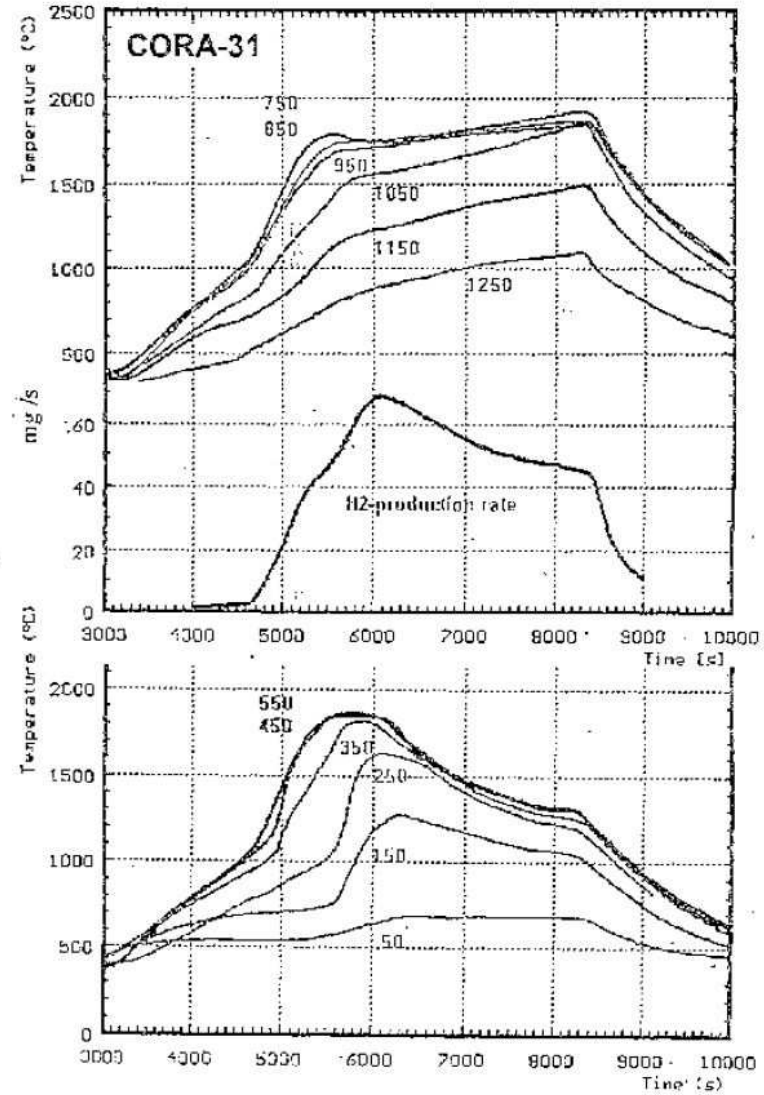
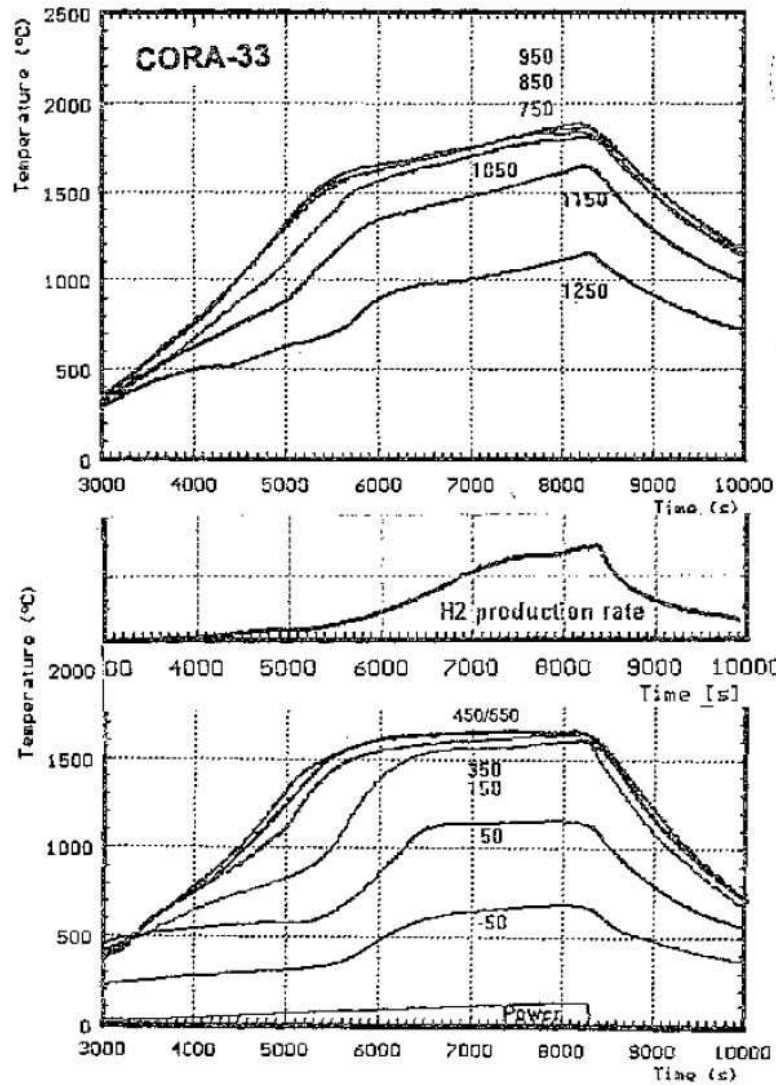

Comparison of temperatures with hydrogen production (CORA-33 / CORA-31).

## **Lack of damage in fuel elements (4)**

The main difference is the lack of temperature escalation and the production of a substantial amount of hydrogen before fuel rod degradation.

Comparing the CORA 33 conditions with the situation in the draining SFP, the time and extent of the observed damage in CORA 33 is mainly caused by the melting of the absorber plate while no absorber plates are present in the SFP. From this it can be concluded that blockages will occur later in the SFP and the hydrogen production without fuel rod damage will be larger than in CORA 33.

From this it can be concluded that in case of syphoning and dry-out of the SFP, a substantial amount of hydrogen can be produced without observable fuel damage and substantial fuel rod failures due to steam starved conditions.

## Added in Rev3: Additional supporting findings

In October 2010 a paper was published by a group of researchers led by A. Stohl “Xenon-133 and caesium-137 releases into the atmosphere from the Fukushima Dai-ichi nuclear power plant: determination of the source term, atmospheric dispersion, and deposition” (<http://www.atmos-chem-phys-discuss.net/11/28319/2011/acpd-11-28319-2011.html>) present the finding that a substantial amount of Cesium 137 was released from the SPF of Block4. This can be seen from the fact that the radioactive release from the damaged plant stopped immediately after the reflooding of the SPF of Block 4. These findings support the author’s conclusions that – though seemingly undamaged at the top – a substantial amount of fuel rod have failed in the SPF of Block 4

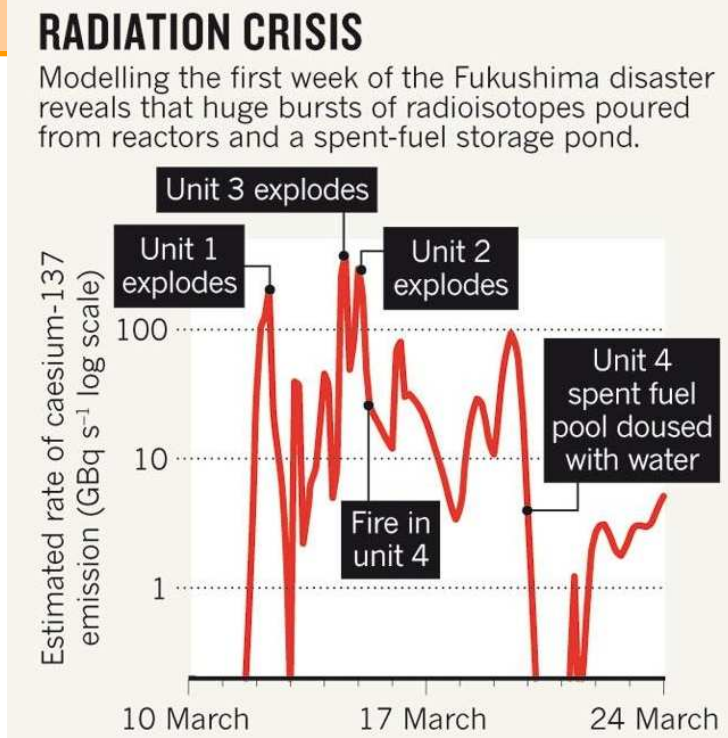

## **Summary**

This analysis presents a hypothesis which explains why all four SFPs in Fukushima experienced a hydrogen explosion.

The cause of these explosions could be a design flaw of the SFP cooling system, which was not designed with an adequate anti-siphon mechanism in case of station black-out.

Basically the hydrogen explosions prevented a complete loss of coolant and stopped the fuel element burning in the SFPs, limiting the release of radioactivity to the environment.

This hypothesis only holds if there are no anti-siphon and drain protection was installed in the feed line of the SFP or in case the anti-siphon and drain protection failed and remained open.